

Raccords instantanés série 1800

Push-in fittings series 1800

Steckanschlüsse Typ 1800

Champs d'application : air comprimé, vide

Caractéristiques techniques

- construction en laiton nickelé
- poussoir de décrochage en résine (POM)
- pince en acier inoxydable
- joints en caoutchouc anti-huile NBR
- filetage :
 - cylindrique BSP avec joint monté
 - conique BSP avec bague d'étanchéité
- pression d'exercice : $-0,99 \div 15$ bar
- température de travail : $-20^{\circ} \div 80^{\circ}\text{C}$

Areas of application : compressed air, vacuum

Technical features

- construction in nickel plated brass
- thrust ring made of resin (POM)
- collet made of stainless steel
- oil-proof rubber packings NBR
- thread :
 - parallel BSP with O-ring
 - taper BSP with seal-edge ring
- working pressure : $-0,99 \div 15$ bar
- working temperature : $-20^{\circ} \div 80^{\circ}\text{C}$

Anwendungsbereiche : Druckluft, Vakuum

Technische Daten

- Körper : Messing vernickelt
- Lösering : Polyacetal (POM)
- Spannring aus Edelstahl
- ölbeständige Gummidichtung NBR
- Gewinde :
 - zylindrisch BSP mit O-ring
 - kegelig BSP mit Teflon - Dichtung
- Betriebsdruck : $- 0,99 \div 15$ bar
- Betriebstemperatur: $-20^{\circ} \div 80^{\circ}\text{C}$

NB: diamètre 3 sur demande - diameter 3 on request - Durchmesser 3 auf Anfrage



Airfit

Raccords d'implantation

Implantation's fittings

Einschraub-Steckverschraubungen

DROIT MÂLE, FILETAGE UNIVERSEL CONIQUE BSP / NPT

MALE STRAIGHT FITTING, UNIVERSAL THREAD BSP / NPT, TAPER

GERADE EINSCHRAUBVERSCHRAUBUNG, UNIVERSALES GEWINDE BSP / NPT - KEGELIG

4900

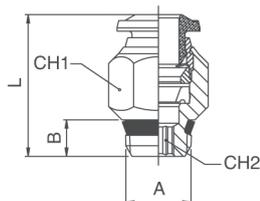

TYPE	TUBE	A	B	L	CH1	CH2
CODE						
4900 04 10	4	1/8	5,5	18	11	3
4900 04 13	4	1/4	7	19	14	3
4900 05 10	5	1/8	5,5	20	11	4
4900 05 13	5	1/4	7	20	14	4
4900 06 10	6	1/8	5,5	21,5	13	4
4900 06 13	6	1/4	7	21	14	4
4900 06 17	6	3/8	7,5	23	17	4
4900 06 21	6	1/2	9	23,5	21	4
4900 08 10	8	1/8	5,5	24,5	14	5
4900 08 13	8	1/4	7	22	14	6
4900 08 17	8	3/8	7,5	23	17	6
4900 08 21	8	1/2	9	23,5	21	6
4900 10 13	10	1/4	7	28	17	7
4900 10 17	10	3/8	7,5	25,5	17	8
4900 10 21	10	1/2	9	26	21	8
4900 12 13	12	1/4	7	31,5	20	7
4900 12 17	12	3/8	7,5	29,5	20	9
4900 12 21	12	1/2	9	31,5	21	10
4900 14 17	14	3/8	7,5	33	21	9
4900 14 21	14	1/2	9	32	21	10

DROIT MÂLE CYLINDRIQUE

MALE STRAIGHT FITTING, PARALLEL

GERADE EINSCHRAUBVERSCHRAUBUNG-ZYLINDRISCH

1801

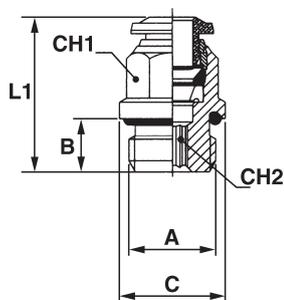

TYPE	TUBE	A	B	C	L1	CH1	CH2
CODE							
1801 04 03	4	M3	3	10	21	-	8
1801 04 05	4	M5	4	8	21	10	2
1801 04 10	4	1/8	6	13	20	10	3
1801 04 13	4	1/4	8	16	19,5	16	3
1801 05 10	5	1/8	6	13	22	12	4
1801 06 05	6	M5	4	10	24,5	13	2
1801 06 10	6	1/8	6	13	23,5	13	4
1801 06 13	6	1/4	8	16	23,5	13	4
1801 08 10	8	1/8	6	13	25	14	5
1801 08 13	8	1/4	8	16	23	14	6
1801 08 17	8	3/8	9	20	24	14	6
1801 08 21	8	1/2	10	25	26,5	14	6
1801 10 13	10	1/4	8	16	30,5	17	6
1801 10 17	10	3/8	9	20	27,5	17	8
1801 10 21	10	1/2	10	25	27	17	8
1801 12 13	12	1/4	8	16	34,5	20	6
1801 12 17	12	3/8	9	20	34	20	8
1801 12 21	12	1/2	10	25	31	22	10
1801 14 17	14	3/8	9	20	35	21	10
1801 14 21	14	1/2	10	25	32	22	11

ÉQUERRE MÂLE ORIENTABLE, FILETAGE UNIVERSEL CONIQUE BSP / NPT

SWIVEL ELBOW MALE FITTING, UNIVERSAL THREAD BSP / NPT - TAPER

WINKLEINSCHRAUBVERSCHRAUBUNG, SCHWENKBAR, UNIVERSALES GEWINDE BSP / NPT - KEGELIG

1805

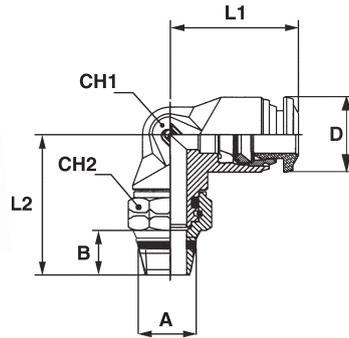

TYPE	TUBE	A	B	D	L1	L2	CH1	CH2
CODE								
1805 04 10	4	1/8	5,5	10	18	19,5	9	13
1805 04 13	4	1/4	7	10	18	21	9	15
1805 05 10	5	1/8	5,5	12,5	20	21,5	11	13
1805 06 10	6	1/8	5,5	12,5	21	21,5	11	13
1805 06 13	6	1/4	7	12,5	21	23	11	15
1805 08 10	8	1/8	5,5	14,5	22,5	24	12	13
1805 08 13	8	1/4	7	14,5	22,5	24	12	15
1805 08 17	8	3/8	7,5	14,5	22,5	24,5	12	17
1805 08 21	8	1/2	9	14,5	22,5	27	12	21
1805 10 13	10	1/4	7	17,5	26,5	26,5	14	16
1805 10 17	10	3/8	7,5	17,5	26,5	24,5	14	17
1805 10 21	10	1/2	9	17,5	26,5	27	14	21
1805 12 17	12	3/8	7,5	21,5	31,5	26,5	16	20
1805 12 21	12	1/2	9	21,5	31,5	29	16	21
1805 14 17	14	3/8	7,5	21,5	31,5	27	16	20
1805 14 21	14	1/2	9	21,5	31,5	29,5	16	21

ÉQUERRE MÂLE ORIENTABLE CYLINDRIQUE

SWIVEL MALE ELBOW FITTING, PARALLEL

WINKLEINSCHRAUBVERSCHRAUBUNG, SCHWENKBAR-ZYLINDRISCH

1806

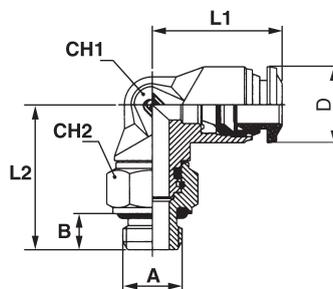

TYPE	TUBE	A	B	D	L1	L2	CH1	CH2
CODE								
1806 04 05	4	M5	3,5	10	18	17,5	9	8
1806 04 10	4	1/8	5,5	10	18	18	9	13
1806 04 13	4	1/4	7	10	18	18	9	16
1806 05 10	5	1/8	5,5	12,5	20	20	11	13
1806 06 05	6	M5	3,5	12,5	21	20	11	11
1806 06 10	6	1/8	5,5	12,5	21	20	11	13
1806 06 13	6	1/4	7	12,5	21	21,5	11	16
1806 08 10	8	1/8	5,5	14,5	22,5	22,5	12	13
1806 08 13	8	1/4	7	14,5	22,5	23	12	16
1806 08 17	8	3/8	8	14,5	22,5	25	12	20
1806 08 21	8	1/2	10	14,5	22,5	26,5	12	25
1806 10 13	10	1/4	7	17,5	26,5	25,5	14	16
1806 10 17	10	3/8	8	17,5	26,5	25	14	20
1806 10 21	10	1/2	10	17,5	26,5	26,5	14	25
1806 12 13	12	1/4	8	21,5	31,5	27,5	16	20
1806 12 17	12	3/8	8	21,5	31,5	27	16	20
1806 12 21	12	1/2	10	21,5	31,5	28,5	16	25
1806 14 17	14	3/8	8	21,5	31,5	27,5	16	20
1806 14 21	14	1/2	10	21,5	31,5	29	16	25

Raccords d'implantation

Implantation's fittings

Einschraub-Steckverschraubungen

ÉQUERRE MÂLE FIXE CONIQUE

MALE ELBOW FITTING, TAPER

WINKLEINSCHRAUBVERSCHRAUBUNG-KEGELIG

1810

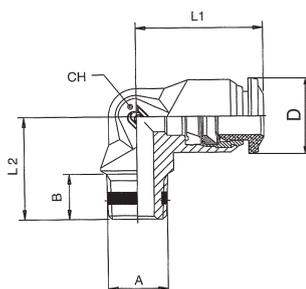

TYPE	TUBE	A	B	D	L1	L2	CH
CODE							
1810 04 10	4	1/8	7,5	10	17	15,5	9
1810 05 10	5	1/8	7,5	12,5	20	17,5	11
1810 06 10	6	1/8	7,5	12,5	21	17,5	11
1810 06 13	6	1/4	11	12,5	21	21,5	11
1810 08 10	8	1/8	7,5	14	22,5	19	13
1810 08 13	8	1/4	11	14	22,5	21,5	13
1810 10 13	10	1/4	11	17	26,5	24,5	16
1810 10 17	10	3/8	11,5	17	26,5	24	16
1810 12 17	12	3/8	11,5	21,5	30,5	28	19

ÉQUERRE PROLONGÉE, MÂLE ORIENTABLE CONIQUE

EXTENDED SWIVEL ELBOW MALE FITTING, TAPER

LANGE WINKLEINSCHRAUBVERSCHRAUBUNG, SCHWENKBAR-KEGELIG

1815

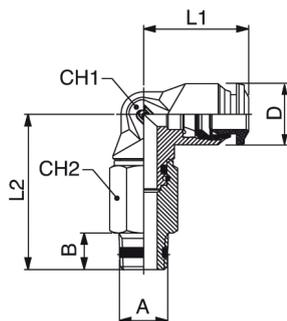

TYPE	TUBE	A	B	D	L1	L2	CH1	CH2
CODE								
1815 04 10	4	1/8	5,5	10	18	31,5	9	12
1815 04 13	4	1/4	7	10	18	33	9	15
1815 06 10	6	1/8	5,5	12,5	21	36	11	12
1815 06 13	6	1/4	7	12,5	21	37,5	11	15
1815 08 10	8	1/8	5,5	14,5	22,5	40,5	12	12
1815 08 13	8	1/4	7	14,5	22,5	40,5	12	15
1815 08 17	8	3/8	7,5	14,5	22,5	41	12	16
1815 10 13	10	1/4	7	17,5	26,5	46	14	15
1815 10 17	10	3/8	7,5	17,5	26,5	44	14	17

DROIT FEMELLE CYLINDRIQUE

FEMALE STRAIGHT FITTING, PARALLEL

GERADE AUFSCHRAUBVERSCHRAUBUNG-ZYLINDRISCH

1803

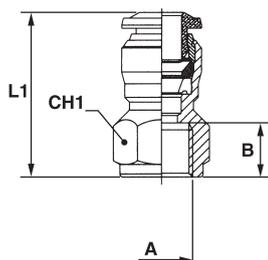

TYPE	TUBE	A	B	L1	CH1
CODE					
1803 04 05	4	M5	5,5	21	11
1803 04 10	4	1/8	8,5	24	13
1803 04 13	4	1/4	11	27,5	16
1803 05 10	5	1/8	8,5	26,5	13
1803 06 10	6	1/8	8,5	26	13
1803 06 13	6	1/4	11	29,5	16
1803 08 10	8	1/8	8,5	27	15
1803 08 13	8	1/4	11	29,5	17
1803 08 17	8	3/8	12	32	19
1803 10 13	10	1/4	11	32	18
1803 10 17	10	3/8	12	33,5	19
1803 10 21	10	1/2	15	39	24
1803 12 17	12	3/8	12	36	21
1803 12 21	12	1/2	15	41	24

T PIQUAGE CENTRAL, MÂLE ORIENTABLE, FILETAGE UNIVERSEL CONIQUE BSP / NPT

SWIVEL CENTRAL BRANCH T MALE FITTING, UNIVERSAL THREAD BSP / NPT - TAPER

ZENTRALE T-EINSCHRAUBVERSCHRAUBUNG, UNIVERSALES GEWINDE BSP / NPT - KEGELIG

1808

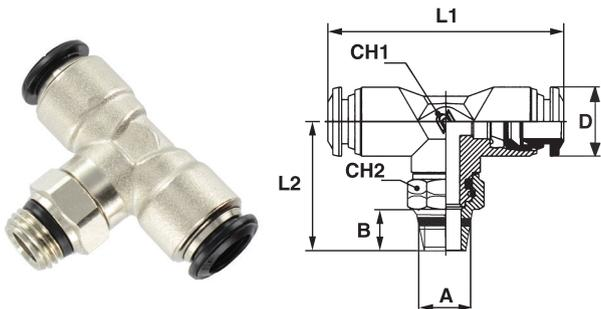

TYPE	TUBE	A	B	D	L1	L2	CH1	CH2
CODE								
1808 04 10	4	1/8	5,5	10	34	20	9	13
1808 04 13	4	1/4	7	10	34	21,5	9	15
1808 05 10	5	1/8	5,5	12,5	40	22	11	13
1808 06 10	6	1/8	5,5	12,5	42	22	11	13
1808 06 13	6	1/4	7	12,5	42	23,5	11	15
1808 08 10	8	1/8	5,5	14,5	45	25,5	13	13
1808 08 13	8	1/4	7	14,5	45	25,5	13	15
1808 08 17	8	3/8	7,5	14,5	45	26	13	17
1808 08 21	8	1/2	9	14,5	45	28,5	13	21
1808 10 13	10	1/4	7	17,5	53	29	14	16
1808 10 17	10	3/8	7,5	17,5	53	27	14	17
1808 10 21	10	1/2	9	17,5	53	29,5	14	21
1808 12 17	12	3/8	7,5	21,5	62,5	29,5	16	20
1808 12 21	12	1/2	9	21,5	62,5	32	16	21
1808 14 17	14	3/8	7,5	21,5	62,5	29,5	16	20
1808 14 21	14	1/2	9	21,5	62,5	32	16	21

T PIQUAGE CENTRAL, MÂLE ORIENTABLE CYLINDRIQUE

SWIVEL CENTRAL BRANCH T MALE FITTING, PARALLEL

ZENTRALE T-EINSCHRAUBVERSCHRAUBUNG, SCHWENKBAR-ZYLINDRISCH

1809

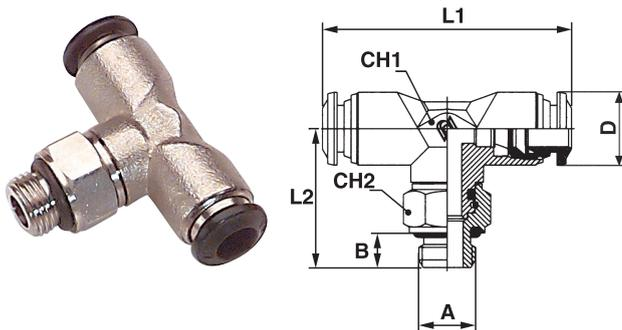

TYPE	TUBE	A	B	D	L1	L2	CH1	CH2
CODE								
1809 04 05	4	M5	3,5	10	34	18	9	8
1809 04 10	4	1/8	5,5	10	34	18,5	9	13
1809 04 13	4	1/4	7	10	34	20	9	16
1809 05 10	5	1/8	5,5	12,5	40	20,5	11	13
1809 06 10	6	1/8	5,5	12,5	42	20,5	11	13
1809 06 13	6	1/4	7	12,5	42	22	11	16
1809 08 10	8	1/8	5,5	14,5	45	23,5	13	13
1809 08 13	8	1/4	7	14,5	45	24	13	16
1809 10 13	10	1/4	7	17,5	53	27,5	14	16
1809 10 17	10	3/8	8	17,5	53	27	14	20
1809 10 21	10	1/2	10	17,5	53	28,5	14	25
1809 12 17	12	3/8	8	21,5	62,5	29,5	16	20
1809 12 21	12	1/2	10	21,5	62,5	31	16	25
1809 14 17	14	3/8	8	21,5	62,5	29,5	16	20
1809 14 21	14	1/2	10	21,5	62,5	31	16	25

Raccords d'implantation

Implantation's fittings

Einschraub-Steckverschraubungen

T PIQUAGE EN BOUT, MÂLE ORIENTABLE, FILETAGE UNIVERSEL CONIQUE BSP / NPT

SWIVEL LATERAL MALE T, UNIVERSAL THREAD BSP / NPT - TAPER

L-EINSCHRAUBVERSCHRAUBUNG, UNIVERSALES GEWINDE BSP / NPT - KEGELIG

1812

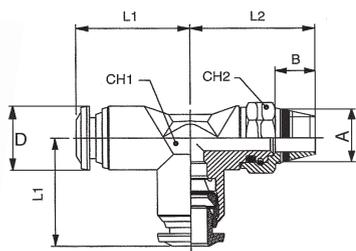

TYPE	TUBE	A	B	D	L1	L2	CH1	CH2
CODE								
1812 04 10	4	1/8	5,5	10	17	20	9	13
1812 04 13	4	1/4	7	10	17	21,5	9	15
1812 05 10	5	1/8	5,5	12,5	20	22	11	13
1812 06 10	6	1/8	5,5	12,5	21	22	11	13
1812 06 13	6	1/4	7	12,5	21	23,5	11	15
1812 08 10	8	1/8	5,5	14,5	22,5	25	13	13
1812 08 13	8	1/4	7	14,5	22,5	25	13	15
1812 08 17	8	3/8	7,5	14,5	22,5	28	13	17
1812 10 13	10	1/4	7	17,5	26,5	26	14	16
1812 10 17	10	3/8	7,5	17,5	26,5	26	14	17
1812 10 21	10	1/2	9	17,5	26,5	28,5	14	21
1812 12 17	12	3/8	7,5	21,5	31,5	29,5	16	20
1812 12 21	12	1/2	9	21,5	31,5	32	16	21

T PIQUAGE EN BOUT, MÂLE ORIENTABLE CYLINDRIQUE

SWIVEL LATERAL MALE T, PARALLEL

L-EINSCHRAUBVERSCHRAUBUNG, SCHWENKBAR-ZYLINDRISCH

1813

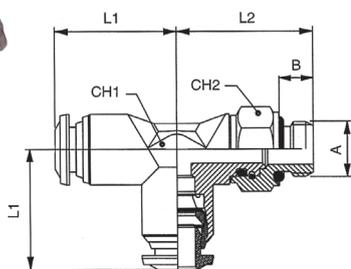

TYPE	TUBE	A	B	L1	L2	CH1	CH2
CODE							
1813 04 05	4	M5	3,5	17	18	9	8
1813 04 10	4	1/8	5,5	17	18,5	9	13
1813 04 13	4	1/4	7	17	20	9	16
1813 05 10	5	1/8	5,5	20	20,5	11	13
1813 06 10	6	1/8	5,5	21	20,5	11	13
1813 06 13	6	1/4	7	21	22	11	16
1813 08 10	8	1/8	5,5	22,5	22,5	13	13
1813 08 13	8	1/4	7	22,5	24	13	16
1813 10 13	10	1/4	7	26,5	27	14	16
1813 10 17	10	3/8	8	26,5	26,5	14	20
1813 10 21	10	1/2	10	26,5	28	14	25
1813 12 17	12	3/8	8	31,5	29,5	16	20
1813 12 21	12	1/2	10	31,5	31	16	25

Y MÂLE ORIENTABLE, FILETAGE UNIVERSEL CONIQUE BSP / NPT

SWIVEL Y MALE FITTING, UNIVERSAL THREAD BSP / NPT, TAPER

Y-EINSCHRAUBVERSCHRAUBUNG, SCHWENKBAR, UNIVERSALES GEWINDE BSP / NPT-KEGELIG

4935

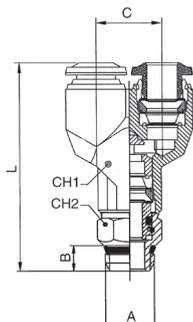

TYPE	TUBE	A	B	C	L	CH1	CH2
CODE							
4935 04 10	4	1/8	5,5	11	38	10	11
4935 06 10	6	1/8	5,5	13,5	43	12	11
4935 06 13	6	1/4	7	13,5	45,5	12	14
4935 08 10	8	1/8	5,5	15,5	46,5	14	11
4935 08 13	8	1/4	7	15,5	49	14	14
4935 08 17	8	3/8	7,5	15,5	49,5	14	17
4935 10 17	10	3/8	7,5	19	57,5	17	17
4935 12 21	12	1/2	9	22	68	20	21

DROIT DOUBLE
 INTERMEDIATE STRAIGHT FITTING
 GERADER VERBINDER

1802

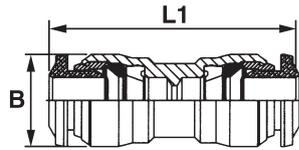

TYPE	TUBE	B	L1
CODE			
1802 04 00	4	10,5	30,5
1802 05 00	5	11,5	33
1802 06 04	6-4	12,5	32
1802 06 00	6	12,5	34
1802 08 06	8-6	14,5	35
1802 08 00	8	14,5	36
1802 10 08	10-8	17,5	40,5
1802 10 00	10	17,5	42
1802 12 10	12-10	20,5	45,5
1802 12 00	12	20,5	47
1802 14 00	14	21,5	49

ÉQUERRE ÉGALE
 INTERMEDIATE ELBOW FITTING
 WINKELVERBINDER

1807

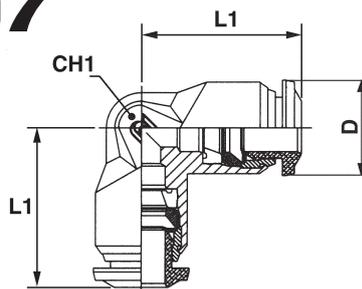

TYPE	TUBE	D	L1	CH1
CODE				
1807 04 00	4	10	17	9
1807 05 00	5	12,5	20	11
1807 06 00	6	12,5	21	11
1807 08 00	8	14	22,5	13
1807 10 00	10	17	26,5	16
1807 12 00	12	21,5	30,5	19
1807 14 00	14	21,5	32,5	19

T ÉGAL
 INTERMEDIATE T FITTING
 T-VERBINDER

1814

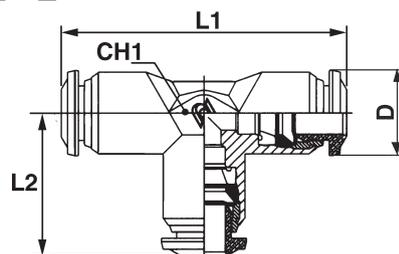

TYPE	TUBE	D	L1	L2	CH1
CODE					
1814 04 00	4	10	34	17	9
1814 05 00	5	12,5	40	20	11
1814 06 00	6	12,5	42	21	11
1814 08 00	8	14	45	22,5	13
1814 10 00	10	17	53	26,5	16
1814 12 00	12	21,5	61	30,5	19
1814 14 00	14	21,5	65,5	32,5	19

Raccords de jonction

Junction's fittings

Verbindungsverschraubungen

TRAVERSÉE DE CLOISON ÉGALE

BULKHEAD INTERMEDIATE FITTING
SCHOTT-VERSCHRAUBUNG

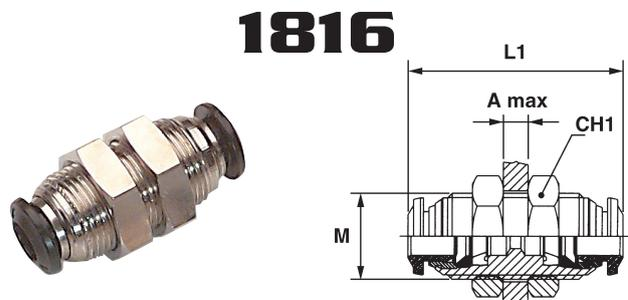

TYPE	TUBE	A max	M	L1	CH1
CODE					
1816 04 00	4	7	M12x1	31,5	17
1816 05 00	5	7	M14x1	33	17
1816 06 00	6	9,5	M14x1	35	17
1816 08 00	8	10,5	M16x1	37	19
1816 10 00	10	12,5	M20x1	43	24
1816 12 00	12	16,5	M22x1	48	26

Y ÉGAL

INTERMEDIATE Y FITTING
Y-VERBINDER

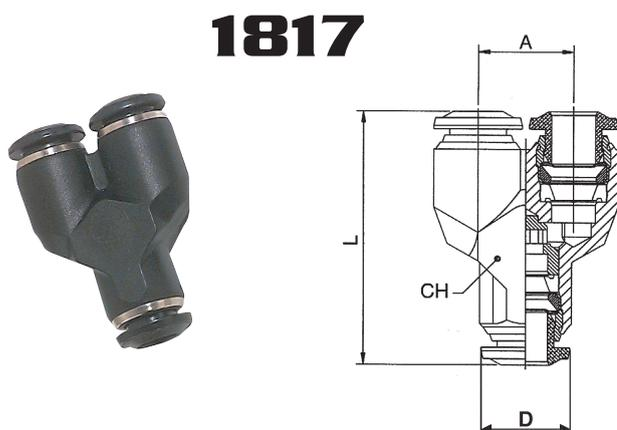

TYPE	TUBE	A	L	D	CH
CODE					
1817 04 00	4	11	31,5	10	10
1817 06 00	6	13,5	37	12	12
1817 08 00	8	15,5	40	14	14
1817 10 00	10	19	48,5	18	17
1817 12 00	12	22	57,5	20	20

RÉDUCTION ENCLIQUETABLE

REDUCER
REDUZIER-STECKER

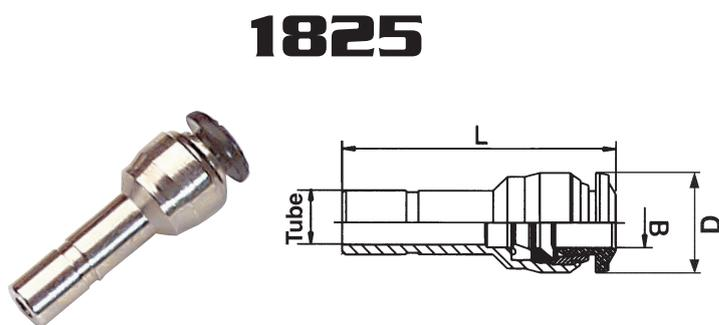

TYPE	TUBE	B	D	L
CODE				
1825 04 06	6	4	10,5	30
1825 05 06	6	5	11,5	34,5
1825 04 08	8	4	10,5	32,5
1825 06 08	8	6	12,5	34,5
1825 04 10	10	4	10,5	31,5
1825 06 10	10	6	12,5	37,5
1825 08 10	10	8	14,5	38,5
1825 08 12	12	8	14,5	39,5
1825 10 12	12	10	17,5	43

ADAPTATEUR UNIVERSEL À BROCHE EN RÉSINE, CYLINDRIQUE

ADAPTOR PLUG, PARALLEL
 GEWINDEANSCHLUßSTECKER-ZYLINDRISCH

1859

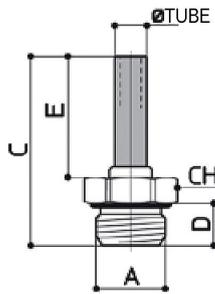

TYPE	TUBE	A	C	D	E	CH
CODE						
1859 04 10	4	1/8	26	5	16	10
1859 06 10	6	1/8	30,5	5	20	11
1859 06 13	6	1/4	31,5	6	20	11
1859 08 10	8	1/8	37	5	22	13
1859 08 13	8	1/4	38	6	22	13
1859 08 17	8	3/8	40	8	22	13
1859 10 13	10	1/4	42	6	24,5	14
1859 10 17	10	3/8	39	8	25	16
1859 12 17	12	3/8	47	8	27	17
1859 12 21	12	1/2	44	9	27	20

BOUCHON EN RÉSINE

RESIN PLUG
 KUNSTSTOFFSTOPFEN

1820

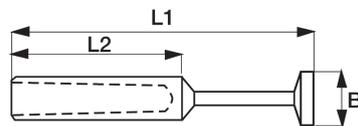

TYPE	TUBE	B	L1	L2
CODE				
1820 04 00	4	5	30	14
1820 06 00	6	7	35	19
1820 08 00	8	9	41	24
1820 10 00	10	10	39	22
1820 12 00	12	12	41	25
1820 14 00	14	16	48	33

JONCTION DOUBLE ENCLIQUETABLE EN RÉSINE

DOUBLE JOINT IN RESIN
 KUNSTSTOFFDOPPELSTECKER

1861

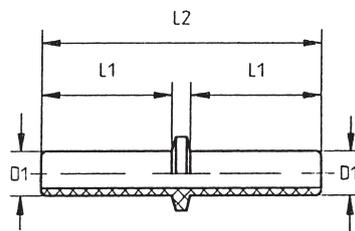

TYPE	D1	L1	L2
CODE			
1861 04 00	4	15	33
1861 06 00	6	18	40
1861 08 00	8	20	45
1861 10 00	10	22	48
1861 12 00	12	25	54
1861 14 00	14	25	54

Raccords banjo

Banjo fittings

Ringstücke

RACCORD BANJO SIMPLE

SINGLE BANJO FITTING
RINGSTÜCK-EINFACH

1821

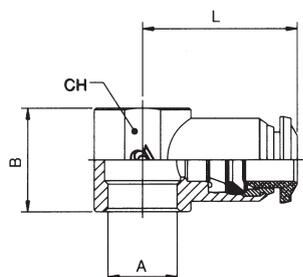

TYPE	TUBE	A	B	L	CH
CODE					
1821 04 05	4	M5	12,5	19	-
1821 04 10	4	1/8	15	21	14
1821 06 10	6	1/8	15	22	14
1821 06 13	6	1/4	17	25	18
1821 08 10	8	1/8	15	24	14
1821 08 13	8	1/4	17	26	18
1821 08 17	8	3/8	20	28	21
1821 10 13	10	1/4	17	29	18
1821 10 17	10	3/8	20	30,5	21
1821 12 17	12	3/8	20	32,5	21
1821 12 21	12	1/2	24	35	25

RACCORD BANJO DOUBLE

DOUBLE BANJO FITTING
RINGSTÜCK-DOPPELT

1822

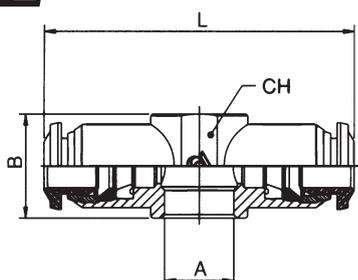

TYPE	TUBE	A	B	L	CH
CODE					
1822 04 05	4	M5	12,5	38	-
1822 04 10	4	1/8	15	42	14
1822 06 10	6	1/8	15	44	14
1822 06 13	6	1/4	17	50	18
1822 08 10	8	1/8	15	48	14
1822 08 13	8	1/4	17	52	18

VIS BANJO SIMPLE

SINGLE HOLLOW BOLT
HOHLSCHRAUBE-EINFACH

1110

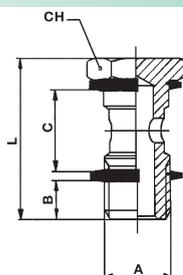

TYPE	A	B	C	L	CH
CODE					
1110 05 01	M5L	4	12,5	22	8
1110 10 00	1/8	5	15	27	14
1110 13 00	1/4	5	17	29,5	17
1110 17 00	3/8	9	20	36	19
1110 21 00	1/2	10	24	42	27

VIS BANJO DOUBLE

DOUBLE HOLLOW BOLT
HOHLSCHRAUBE-DOPPELT

1120

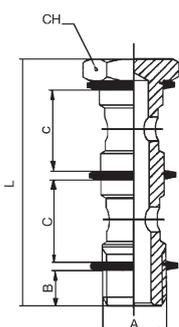

TYPE	A	B	C	L	CH
CODE					
1120 10 00	1/8	6	15	44,5	14
1120 13 00	1/4	8	17	50,5	17
1120 17 00	3/8	9	20	58	19

RÉPARTITEURS 5 VOIES EN ALUMINIUM

ALUMINIUM MANIFOLD 5 WAYS
ALUMINIUM-VERTEILER MIT 5 AUSGÄNGEN

4936

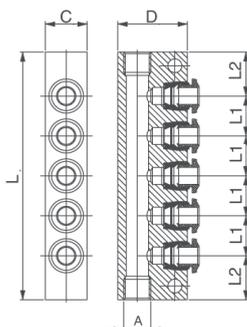

TYPE	TUBE	A	C	D	L	L1	L2
CODE							
4936 04 10	4	1/8	15	25	75	12	13,5
4936 06 10	6	1/8	15	25	90	14,5	16
4936 06 13	6	1/4	20	30	90	14,5	16
4936 08 13	8	1/4	20	30	100	16	18

OUTIL DE DÉCONNEXION

TOOL FOR DISASSEMBLING
LÖSEWERZEUG

4996

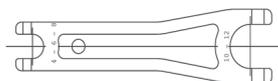

TYPE
CODE
4996 04 12

CLIP DE SÉCURITÉ

SECURITY CLIP
SICHERHEITSClip

4997



TYPE	TUBE
CODE	
4997 04 00	4
4997 05 00	5
4997 06 00	6
4997 08 00	8
4997 10 00	10
4997 12 00	12
4997 14 00	14

